

Linear Regulator Protection Circuitry

Kieran O'Malley
 ON Semiconductor
 2000 South County Trail
 East Greenwich, RI 02818



ON Semiconductor™

<http://onsemi.com>

APPLICATION NOTE

Most monolithic linear regulators contain basic protection features to safeguard against potentially catastrophic events. These features include short circuit and overvoltage protection, thermal shutdown, reverse battery and reverse transient protection. Each of these features effects design performance, system reliability, and cost.

All features may not be necessary or even desirable for a particular system. By gaining a full understanding of each of these features and their implications, a designer can make the appropriate choices about how and which to include in a system design.

Short Circuit Protection

Linear regulators can be destroyed if they are forced to source excessive current. This can happen under short circuit or excessive load conditions. In a short circuit condition, not only is the pass transistor sourcing excessive current, the voltage across it is maximal. (Since V_{OUT} is ground, the voltage across the transistor is V_{IN} .)

Linear regulators typically use one of two types of short circuit protection on chip: constant current limit or foldback current limit.

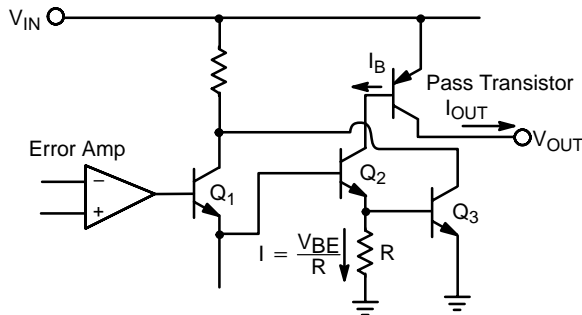

Figure 1. Constant Current Limit Circuit

In a constant current limit circuit, the maximum current that a linear regulator can source is limited to a preset value, I_{MAX} . Figure 1 shows a typical constant current limit circuit. As I_{OUT} increases, I_B in the output device, increases proportionately as I_{OUT}/β . As I_B increases, the base voltage of transistor Q3 ($V_{BE3} = I_B/R$) increases, turning on Q3. Q3's collector current is steered away from Q1, lowering Q1's emitter and Q2's base voltage. The output current reaches an equilibrium point where I_{OUT} is held at a determined maximum value, I_{MAX} .

In a foldback current limiting circuit (Figure 2), the output voltage remains within specification limits up to I_{MAX} . Beyond this level, both the output current and voltage decrease. Their decaying value follows the foldback curve

until the current reaches its I_{FB} at $V_{OUT} = 0$ V (Figure 3). The foldback current limit circuit is similar in design and function to the constant current limit circuit except that it contains feedback elements connected to the output.

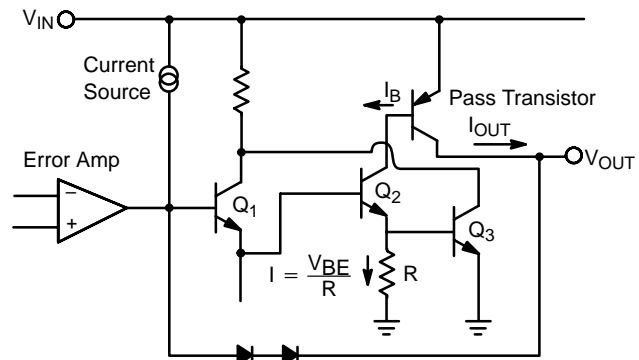

Figure 2. Foldback Current Limit Circuit for the CS8101

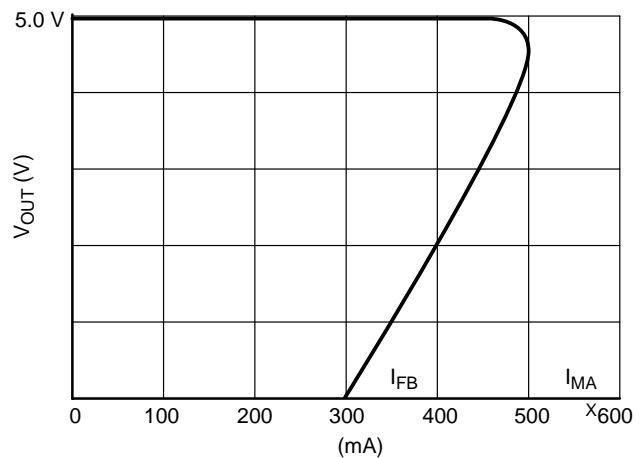

Figure 3. Curve of Foldback Current for a Typical 5.0 V, 500 mA Linear Regulator

The foldback current limit circuit has one advantage over the constant current limit circuit: power dissipation in the pass transistor of the linear regulator will be less because there is less current flowing through it.

There is a potential problem with the foldback current limit method. If, following the removal of the fault condition, the load draws a current anywhere along the foldback current curve, the output value will never reach its nominal value. Instead, the regulator will operate in a “latch up” mode at that voltage and current on the foldback curve (Figure 3).

This situation was observed in one case where a regulator with a foldback current limit circuit powered a smoke alarm system. Under normal conditions, the alarm circuit drew 100 mA. This rose to 400 mA when the alarm sounded. The regulator was set to provide a maximum of 500 mA with a foldback current of 300 mA (Figure 3). If the alarm was on when the system powered up, the load drew the 400 mA but, because that value was along the foldback curve, the regulator’s output voltage never rose to its nominal V_{OUT} value.

A similar response is seen with the constant current limit circuit. During turn-on, if the load draws enough current to send the device into current limit immediately, the output voltage will not rise to its nominal value.

This type of a system fault condition is difficult to predict. Therefore it is advisable to test the regulator under normal operating conditions with minimum and maximum loads and input voltages. The testing should also include switch-ons and switch-offs at all possible temperatures to ensure that the output reaches its nominal voltage level.

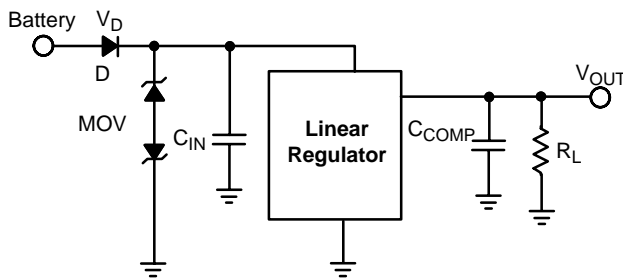

Figure 4. MOV for Both Forward and Reverse Battery Protection

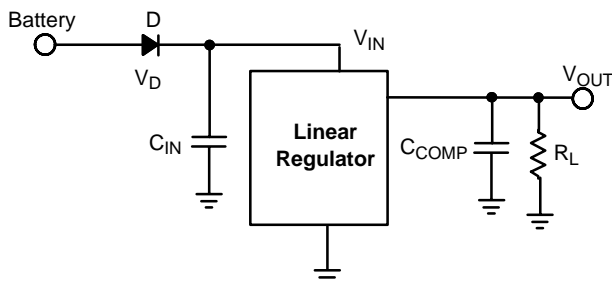

Figure 5. Blocking Diode D for Reverse Battery Protection

When the regulator is powered up, the output capacitor, C_{COMP} presents itself as a short circuit to ground (Figures 4 and 5). The regulator immediately goes into current limit until the capacitor is fully charged up to its nominal output voltage. This means the regulator initially draws the current limit I_{MAX} , plus its quiescent current, I_Q . If there is a component such as a blocking diode in series with the regulator’s input (Figures 4 and 5), that component or diode must be sized to accommodate that maximum current surge not just the expected maximum load current. If the diode is too small, it may be damaged during power up.

Overvoltage Protection

Overvoltage transient or “load dump” protection keeps an IC from “seeing” voltage transients. These transients are introduced by inductive loads from motor windings, alternators, and long wire harnesses. If the transients are of sufficient energy, these spikes can cause catastrophic junction breakdowns on the IC.

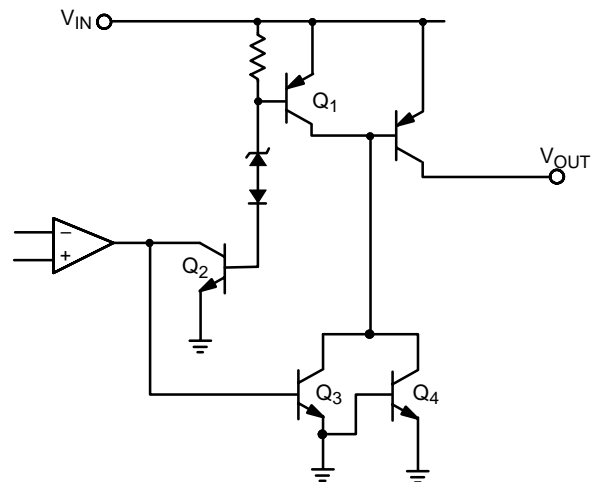

Figure 6. Overvoltage Protection Circuit. Since High Voltage Zeners are Difficult to Fabricate, the Zener Diode Pictured Here is Really Several Zeners in Series. Each Diode in this String has a 7.0 V Drop when Reverse Biased

Figure 6 shows a schematic of an overvoltage protection circuit used in many linear regulators. Under normal input conditions, the protection Zener diode does not conduct and Q1 remains off. When V_{IN} increases beyond 40 V, the Zener diode breaks down and conducts, causing both Q1 and Q2 to saturate. The saturated Q2 turns off the Q3–Q4 darlington driver. The saturated Q1 and the “off” darlington pair ensures that no current is delivered to the load. When the overvoltage condition disappears, the Zener diode shuts off and the output stage conducts normally again. By directing the excess energy to ground and shutting off the regulator’s output, these potentially damaging spikes are not passed on to the load where they might destroy other electronics.

As the designer begins to formulate the system protection requirements, it is important to determine the size and the

energy content of the forward biased voltage transients. If the supply line is already conditioned, additional on or off chip transient protection may be unnecessary.

To accommodate larger transients (> 100 V), IC designers design with more robust fabrication processes. This results in larger on chip transistors and therefore larger die size, possibly in bigger packages and all at higher costs.

Alternatively, if a regulator with a less than acceptable transient voltage rating is used in a system, both forward and reverse transients can be damped by using an external MOV in parallel with the regulator (Figure 5). The MOV is rated by the amount of energy it can trap and dissipate.

Thermal Shutdown

Under normal operating conditions, the junction temperatures on an IC should not exceed 150°C . The IC's package and heat sink selections are made to ensure that the junction temperature does not exceed 150°C under normal operating conditions. (For more information see the ON Semiconductor applications note, "Thermal Management," document number AND8036/D, available through the Literature Distribution Center or via our website at <http://www.onsemi.com>.)

On chip thermal shutdown circuitry protects the junctions from damage. Figure 7 shows a typical thermal shutdown circuit. As the die temperature rises, the V_{BE} of Q_1 decreases by 2.0 mV/ $^{\circ}\text{C}$, increasing the base voltage of Q_2 . The collector current of Q_2 increases to a value that causes the remainder of the shutdown circuitry to turn off the regulator output stage. As soon as the die temperature drops below a preset level, the regulator resumes normal operation.

If the fault persists, the die will heat up again and the regulator will be switched off until the die cools off. This switching or oscillatory behavior will continue until the fault is removed.

In complex electromechanical systems, thermally related problems are often among the most difficult to diagnose. They are intermittent and appear only when the device heats up to the trigger temperature. While thermal protection is desirable in most applications, there are some situations where it may be better to have the IC fail. In these circumstances, it may be less expensive to replace a system rather than invest the time and effort to diagnose the failure.

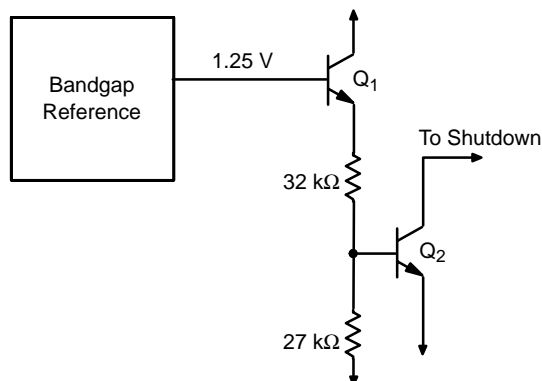

Figure 7. Thermal Shutdown Circuit

Reverse Battery and Reverse Transient Protection

If there is a possibility that a battery might be installed with its polarity reversed, then reverse battery protection may be desirable. If an IC is exposed to a reverse voltage supply, large currents will flow to ground through parasitic junctions in the die. If the currents are sufficiently large, they will destroy fragile junctions in the IC. For this reason, IC designers develop circuits where none of the input voltages are directly connected to an n type silicon region on the die. This solution works well for low drop PNP regulators. However, it is impractical to design on chip reverse battery protection for NPN and composite NPN/PNP regulators.

NPN and NPN/PNP composite regulators rely on off chip reverse battery protection in the form of a blocking diode, MOV, or fuse (Figures 4 and 5). The series diode will be forward biased during normal operation and serve as a blocking diode during reverse battery conditions. However, it does add another voltage drop V_D which effects the dropout voltage of the system and also dissipates power $(I_{OUT} + I_Q)V_D$. The diode must be sized to hold off the worst case steady state reverse battery condition. As mentioned above, if the regulator has current limit circuitry and a compensation capacitor on the output, the diode or fuse must also support the maximum current $(I_{MAX} + I_Q)$ the regulator will draw during its power up phase.

Reverse transient protection is identical to reverse battery protection. Reverse transients, like the forward biased transients derive from inductive loads on the supply line. Fortunately they are mostly high speed, low energy transients that do not last long enough to heat up the IC and cause irreversible damage.

Summary

Each of the above features protects the IC from a specific catastrophic event that might occur during a system failure. While a designer may be initially inclined to incorporate all of the features on chip, this may not be a prudent course. The designer must consider which protection features are necessary. Regulators which have extensive protection features are more expensive. Depending on space, efficiency and cost, it may be less expensive to provide external protection.

SMART REGULATOR is a registered trademark of Semiconductor Components Industries, LLC (SCILLC).

ON Semiconductor and  are trademarks of Semiconductor Components Industries, LLC (SCILLC). SCILLC reserves the right to make changes without further notice to any products herein. SCILLC makes no warranty, representation or guarantee regarding the suitability of its products for any particular purpose, nor does SCILLC assume any liability arising out of the application or use of any product or circuit, and specifically disclaims any and all liability, including without limitation special, consequential or incidental damages. "Typical" parameters which may be provided in SCILLC data sheets and/or specifications can and do vary in different applications and actual performance may vary over time. All operating parameters, including "Typicals" must be validated for each customer application by customer's technical experts. SCILLC does not convey any license under its patent rights nor the rights of others. SCILLC products are not designed, intended, or authorized for use as components in systems intended for surgical implant into the body, or other applications intended to support or sustain life, or for any other application in which the failure of the SCILLC product could create a situation where personal injury or death may occur. Should Buyer purchase or use SCILLC products for any such unintended or unauthorized application, Buyer shall indemnify and hold SCILLC and its officers, employees, subsidiaries, affiliates, and distributors harmless against all claims, costs, damages, and expenses, and reasonable attorney fees arising out of, directly or indirectly, any claim of personal injury or death associated with such unintended or unauthorized use, even if such claim alleges that SCILLC was negligent regarding the design or manufacture of the part. SCILLC is an Equal Opportunity/Affirmative Action Employer.

PUBLICATION ORDERING INFORMATION

Literature Fulfillment:

Literature Distribution Center for ON Semiconductor
P.O. Box 5163, Denver, Colorado 80217 USA
Phone: 303-675-2175 or 800-344-3860 Toll Free USA/Canada
Fax: 303-675-2176 or 800-344-3867 Toll Free USA/Canada
Email: ONlit@hibbertco.com

N. American Technical Support: 800-282-9855 Toll Free USA/Canada

JAPAN: ON Semiconductor, Japan Customer Focus Center
4-32-1 Nishi-Gotanda, Shinagawa-ku, Tokyo, Japan 141-0031
Phone: 81-3-5740-2700
Email: r14525@onsemi.com

ON Semiconductor Website: <http://onsemi.com>

For additional information, please contact your local Sales Representative.